

Phage Display

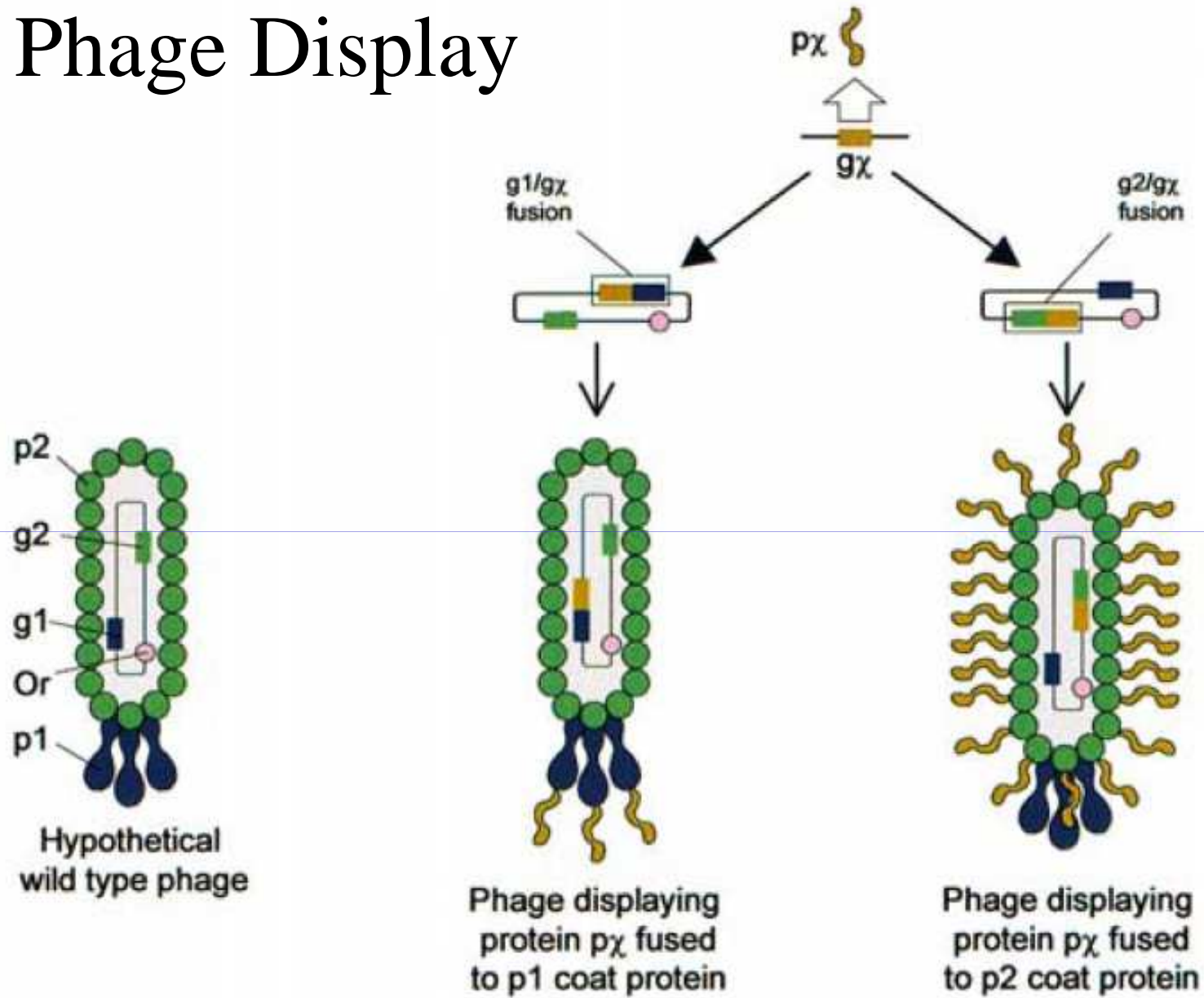

Phage Display

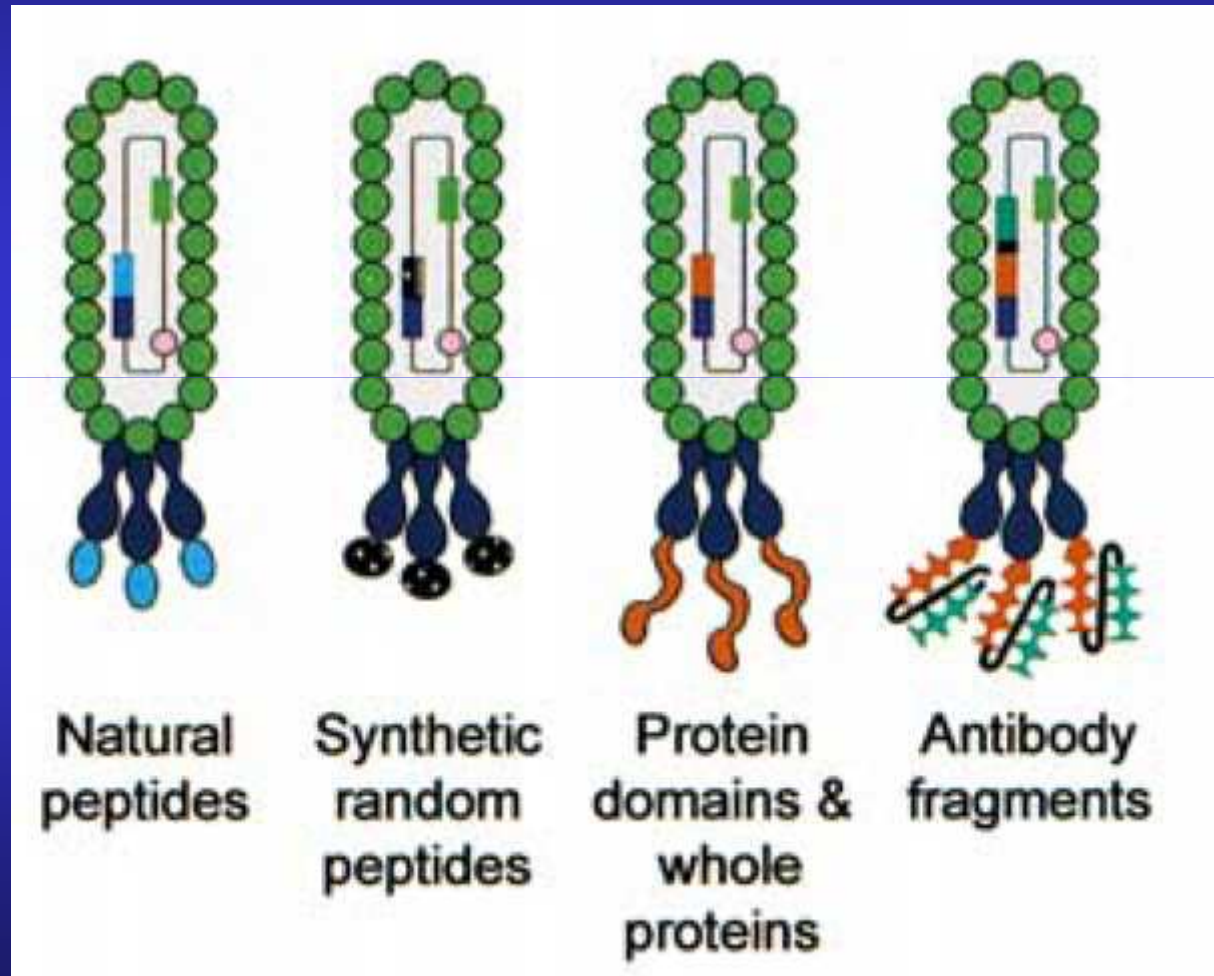

Phage Display

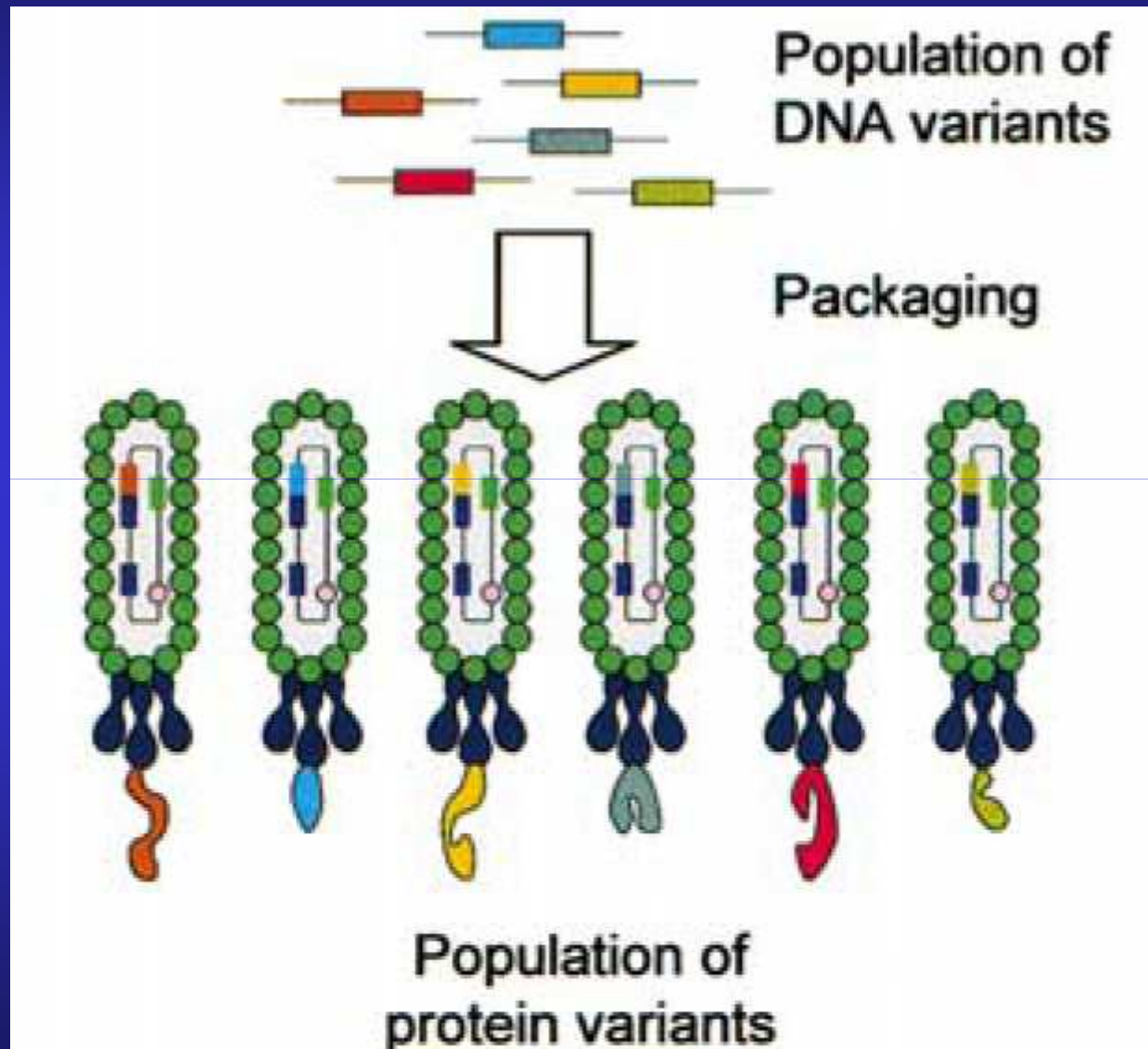

Phage Display

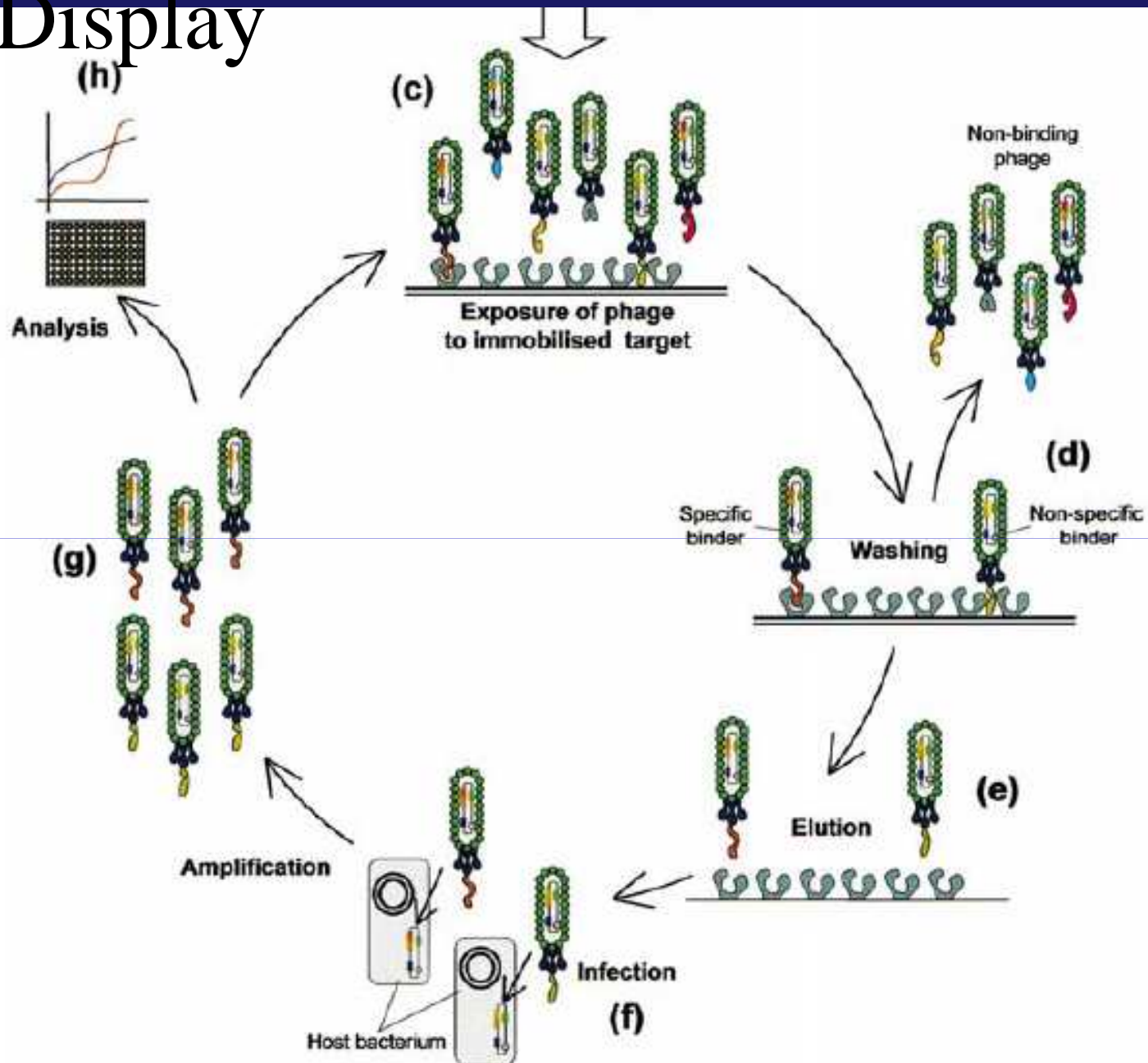

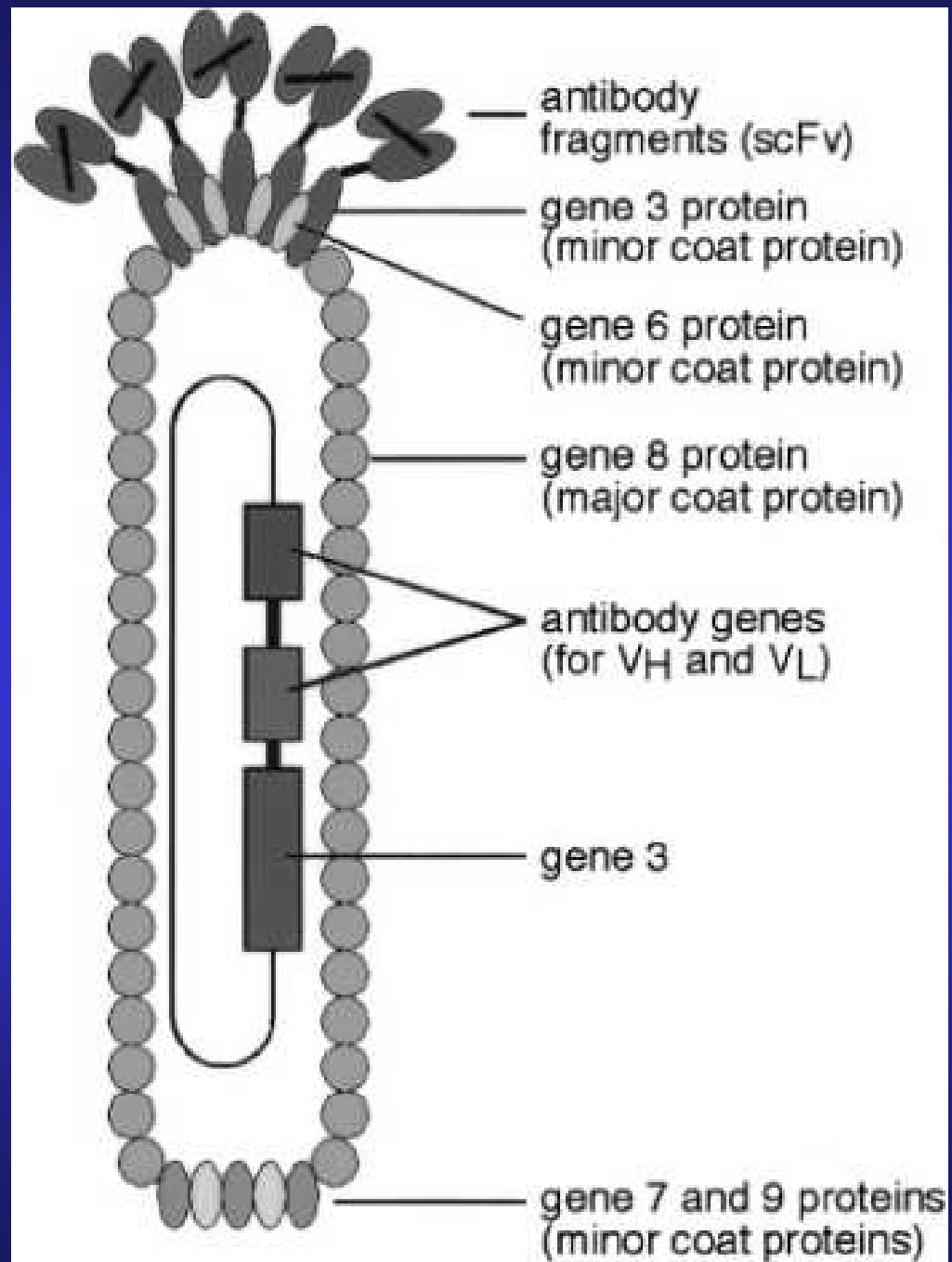

Model of FVIIa protease domain with A-183 extension peptide

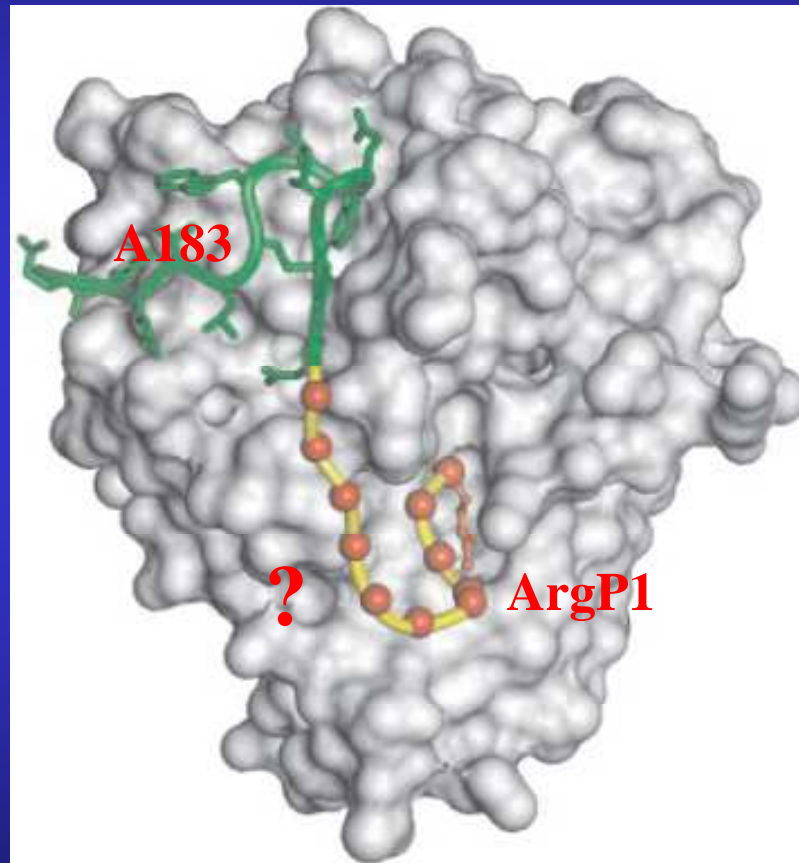

a chimeric peptide with a high degree of specificity and potency:
exosite interactions + greater steric hindrance in the substrate binding cleft + higher affinity due to a more extensive binding surface

determinanti di specificità

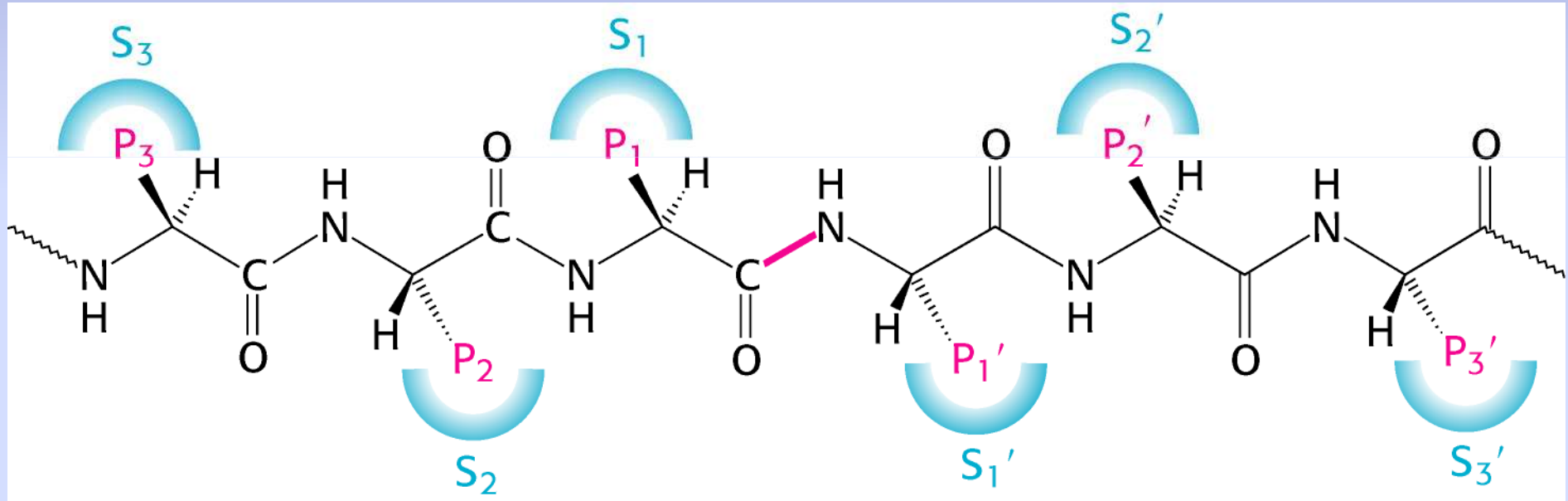
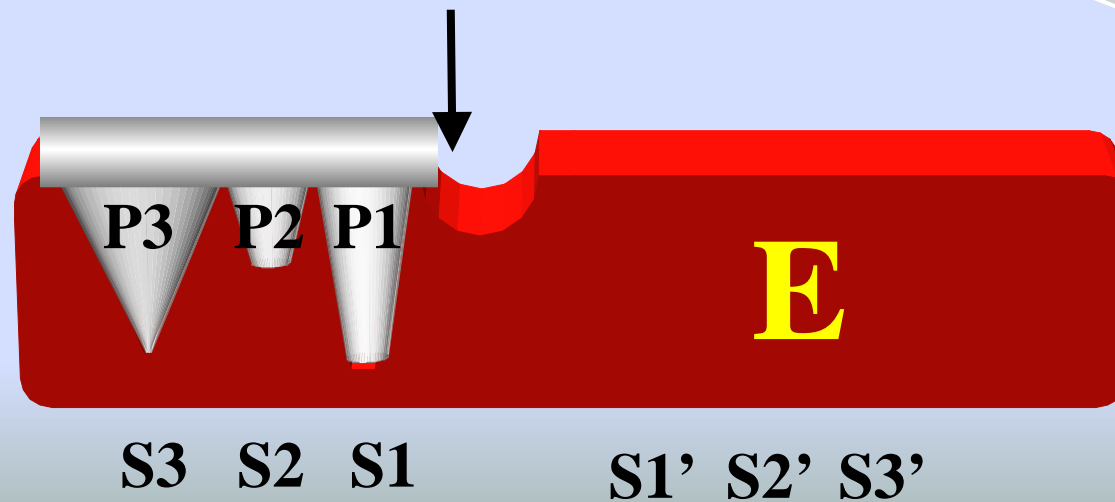
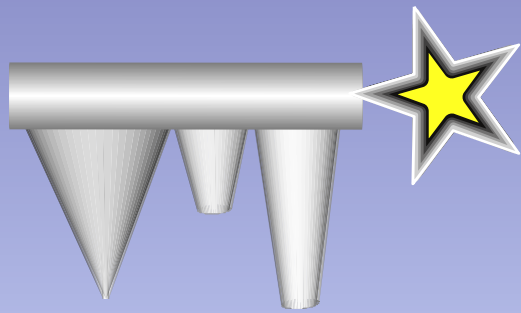

Table 1 Sites of cleavage in the human vitamin K-dependent zymogens*

Enzyme	Substrate†	P ₄	P ₃	P ₂	P ₁	↓	P ₁ '	P ₂ '	P ₃ '	P ₄ '
Xa/Va	II	I	E	G	R		T	A	T	S
	II ₍₁₅₋₁₆₎	I	D	G	R		I	V	E	G
VIIa/TF, IXa/VIIIa	X ₍₁₅₋₁₆₎	N	L	T	R		I	V	G	G
VIIa/TF, XIa	IX	K	L	T	R		A	E	A	V
	IX ₍₁₅₋₁₆₎	D	F	T	R		V	V	G	G
VIIa/TF, Xa	VII ₍₁₅₋₁₆₎	P	Q	G	R		I	V	G	G
IIa/TM	PC ₍₁₅₋₁₆₎	V	D	P	R		L	I	D	G

*Sequences flanking cleavage sites relevant to the activation of the vitamin K-dependent zymogens are presented along with the relevant enzymes that catalyze these reactions. The site of bond cleavage is denoted by the arrow. †The site, in each substrate, at which cleavage is required to produce the serine proteinase is indicated as (15–16) corresponding to the homologous residue numbers in chymotrypsinogen [70].





Oligopeptidyl
Substrate

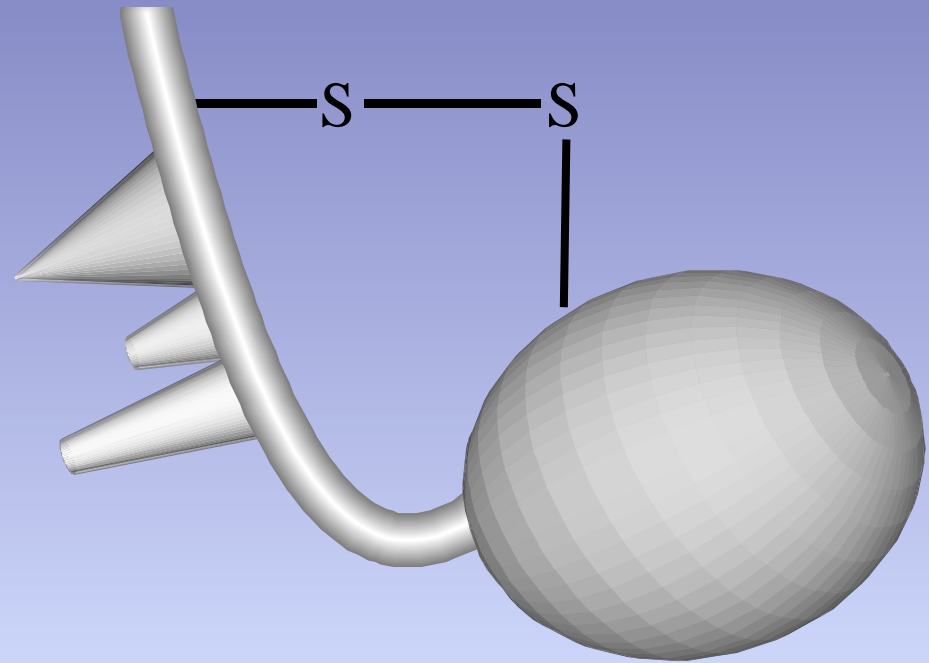

Protein Substrate

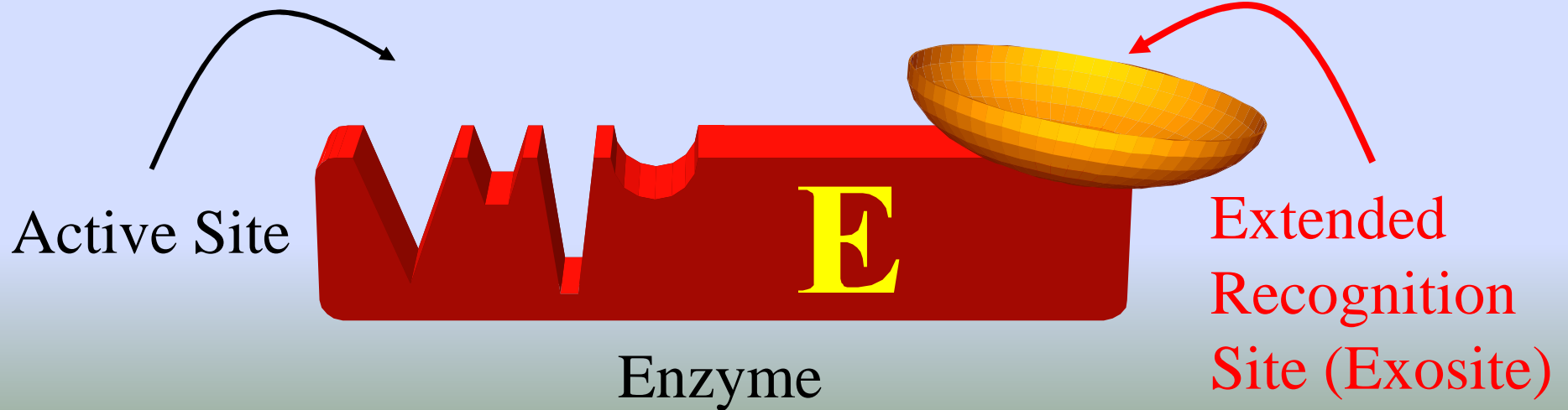

Active Site

Enzyme

Extended
Recognition
Site (Exosite)

Inhibitors of Factor VIIa

Position Library	Anchor	Linker library positions														Spacer	Phage coat protein			
		1	2	3	4	5	6	7	8	9	10	12	14	16						
A		X	X	X	X	X	X	X	a	N	L	T	R	I	V	G	G	-	protease	
B	A-183	X	X	X	X	X	X	X	b	L	T	R	I	V	G	G	-	-	resistant	p3
C		X	X	X	X	X	X	X	c	T	R	I	V	G	G	-	-	-	spacer	
D		G	G	S	G	G	S	G	X	X	X	X	X	X	X	G	G	-		

$a = S, N, K, R; b = N, K; c = L, Q$

Peptide Inhibitors of Factor VIIa: Phage binding

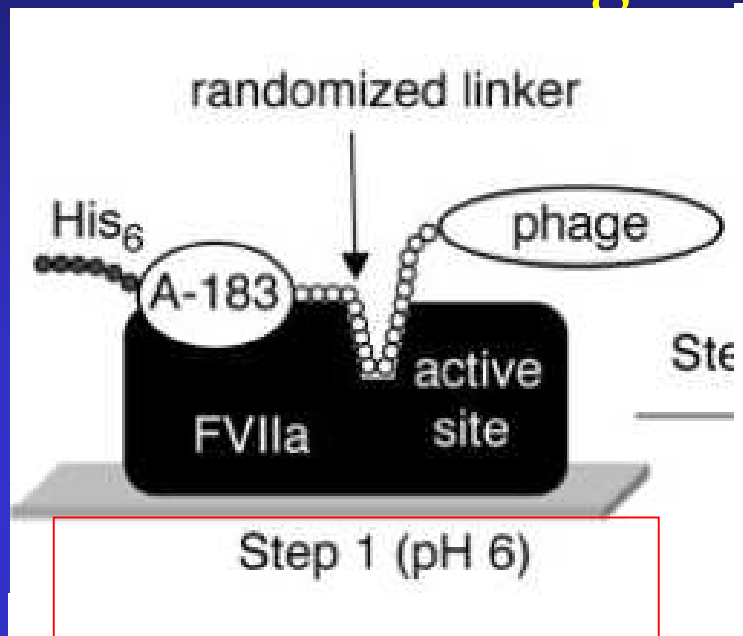

FVIIa Cleavage conditions

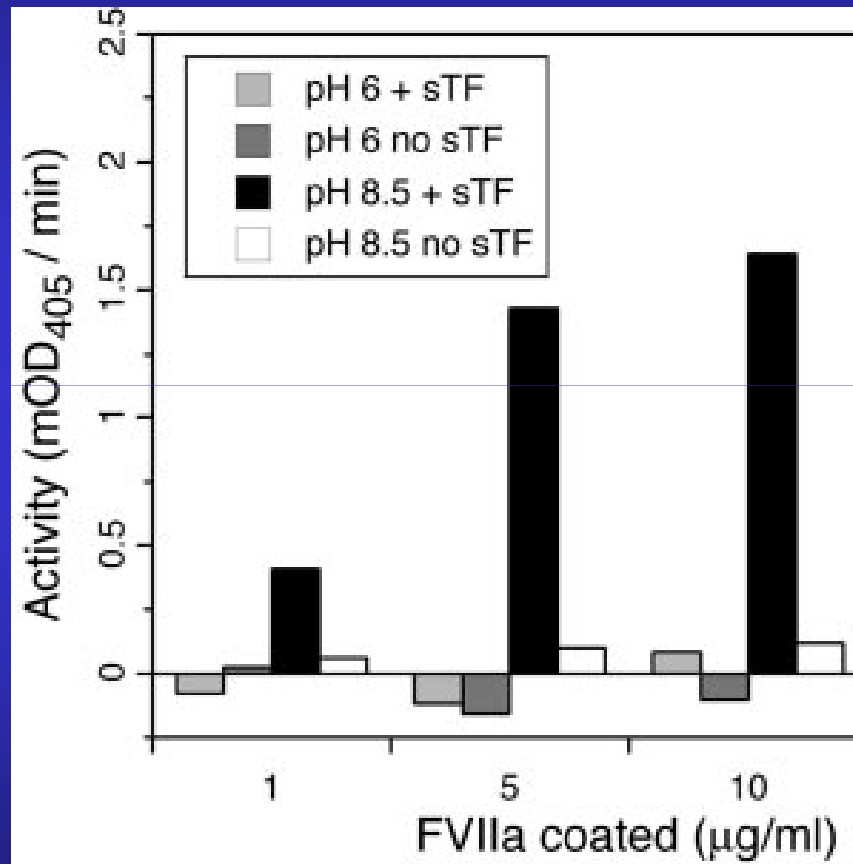

Peptide Inhibitors of Factor VIIa: washing (2) and cleavage (3)

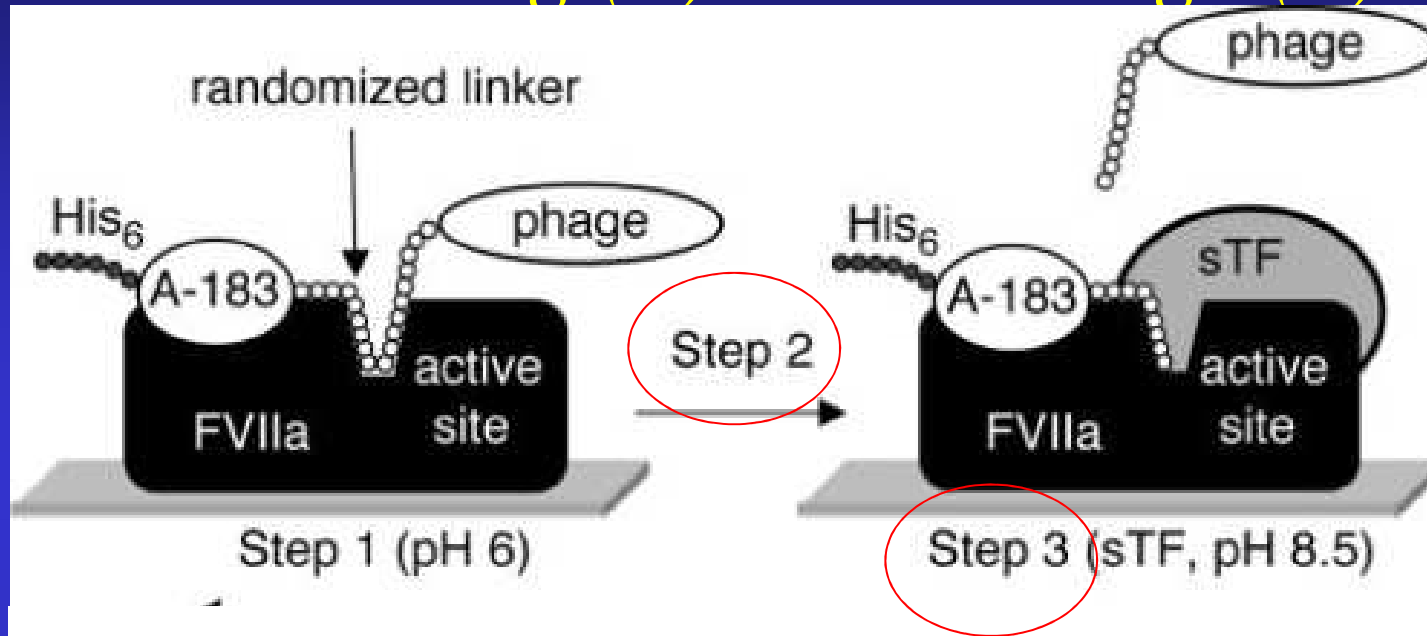

Peptide Inhibitors of Factor VIIa: removal of unbound phages (4)

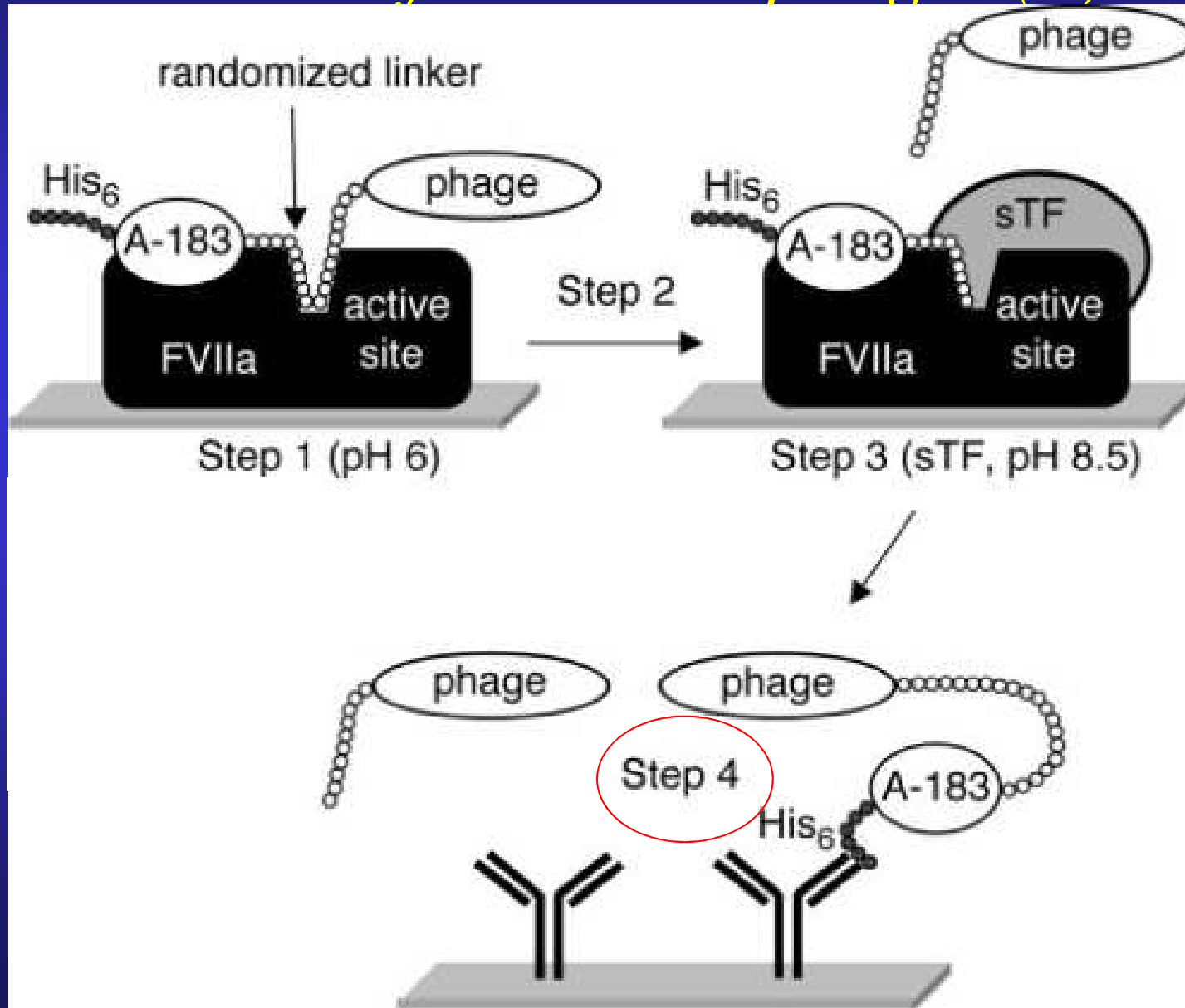

*Peptide Inhibitors of Factor VIIa:
propagation of selected phages and new rounds (5)*

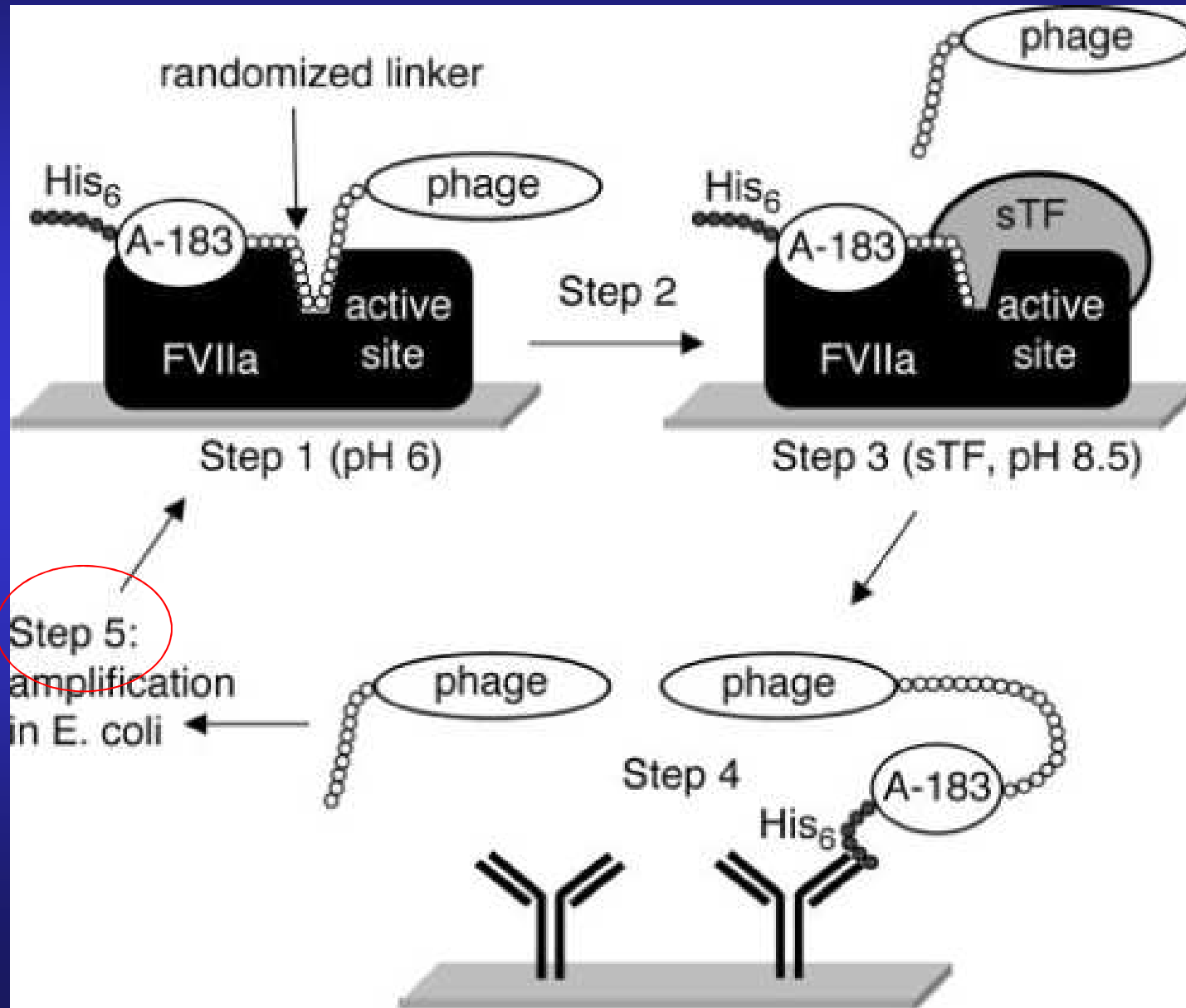

Prolongation of TF-dependent clotting times

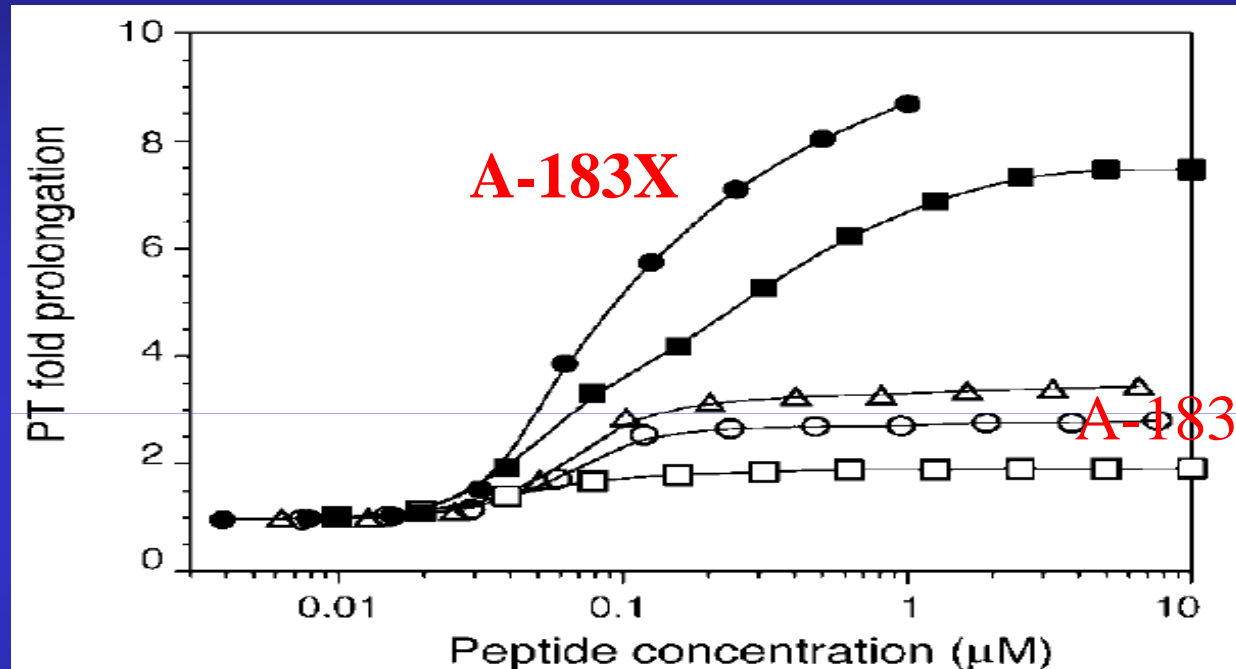

X=EEWEVLCWTWETCERGGVEEELWEWR

A-183X was a potent and complete inhibitor of FX activation, having a maximal extent of inhibition of 99% with an IC₅₀ of 230 pM *versus* A-183 which maximally inhibited to 74% with an IC₅₀ of 1.5 nM.

A-183X also had a maximal prolongation of the prothrombin time of 7.6- *versus* 1.9- fold for A-183, making it a more effective anticoagulant